

| | | |
|------------------------|---------------------|--|
| Specifications: | Frequency Bandwidth | 2250 – 2550MHz (+/- 3dB) |
| | Gain | 25dB Total MGA86576 / MAV-11 |
| | Noise Figure | <2dB Typically 1.8dB |
| | Local Oscillator | Mini-Circuits POS2000 VCO 1370 – 2000MHz |
| | I/F Output | Typically 900 to 1000MHz |
| | Power | 12volts 100mA |

CIRCUIT DESCRIPTION: The complete receive converter is built on a single 55 x 86mm size PC Board & takes around 2.5 hours to build. The converter is a broadband NO-Tune design using hairpin filters that cover 2250 to 2550MHz & uses surface mount components that are mounted on 50ohm striplines for the RF signal paths for consistency in performance, & to ensure that construction errors do not occur due to the different construction techniques used from one constructor to the next. The converter has 25dB gain & a 2db noise figure, & the I/F output frequency is 900-1100MHz, and can be connected directly to the input of a Analogue Satellite receiver. The I/F output can be varied either way by adjusting the VCO frequency, so that local interference close to the I/F can be avoided. The local oscillator uses a Mini-Circuits POS2000 VCO module, & can be locked with the addition of a MC12179 PLL & Crystal. Any drift can be compensated by using the AFT control on the Satellite Receiver. A 3.5GHz ADE-35 Mini-Circuits mixer is used for low loss conversion & for its broad bandwidth.

RECEIVE SECTION: The RF input amplifier stages consist of single MGA86576 HP GaAs MMIC amplifier providing around 23dB gain & a 2dB noise figure at 2400MHz. Bias for the GaAs MMIC amplifier is via a 27ohm resistor from the 8volt regulator. The MGA86576 has an internal self bias network so the bias resistor is not too critical. The RF input stripline filter has a 300MHz -3dB bandwidth from 2250 to 2550MHz with -2.5dB loss maximum.

LOCAL OSCILLATOR: Refer to the circuit diagram. The VCO uses a Mini-Circuits POS2000 voltage controlled oscillator, which can be adjusted for an output between 1216 & 1570MHz with a trimpot from the 8volts that is available from the regulator. The VCO module produces +10dBm output that is attenuated by a 3dB pad before being input to the ADE-35 mixer at +7dBm. Alternatively an optional MC12179 PLL & crystal can be added to lock the oscillator for high stability applications. The MC12179 is a complete single frequency div by 256 PLL with internal oscillator & charge pump cct. For a required VCO frequency of 1450MHz, a 5.664MHz crystal, (1450 div 256) is required as a reference for the MC12179. A portion of the 1450MHz output from the POS2000 is fed back into pin4 of the MC12179 phase comparator.

I/F SECTION: A coaxial shorting stub on the output of the ADE-35 effectively attenuates any residual 1450MHz local oscillator breakthrough from being amplified by the MAV-11 I/F Amplifier. The I/F output signal at 900 – 1100MHz is amplified by around 10dB by the MAV-11, & passes to the I/F output.

CONSTRUCTION:

1. **This Kit uses a Teflon PC board that can be difficult to work, & care must be taken when drilling any holes in the board. Blunt Drill bits seem to be the best if done by hand. A power drill or press should never be used as it will tend to rip the board.** The first part of construction is to cut out along the line etched on the board to fit an N connector socket for the antenna connection. Use a sharp scapel & be careful as the board is very soft. File the center pin of the N connector to length so that it fits the input track on the board. Position the N connector & tack solder the connector into place to get it aligned. Then solder the connector to both sides of the board.
2. Next carefully round the edges of the board with a sharp knife, & fabricate some thin 25mm wide brass strip around the outside of the board to form a box. Start at the N connector & mark & bend it until it fits correctly. Next using a ruler to check the height of the board, tack solder the board to the brass strip. When you are happy with it, solder it all the way around on both sides. Next drill a hole in the brass to mount a suitable connector for the I/F output connection. A F connector socket is suggested as it will suit connection to RG6 cable for use with a Satellite Receiver.
3. The Circuit Board supplied is not a plated through hole board, so 0.7mm TCW links will have to be used to connect the top ground plane earth connections to the bottom grounplane side of the board. These holes are shown as black dots on the PCB overlay diagram. It is best to solder the ADE-35 mixer into place now as some wire links are used around the mixer for earthing. Take note of Pin1, (Dot) on the mixer for correct orientation. The mixer is a SMD device & will require a fine hot soldering iron to flow the solder under the mixers legs to the board. Solder in any remaining wire links that are used for earthing.
4. Follow the PCB overlay diagram and circuit carefully, by checking the components and placing them onto the

board. All components except the POS2000 are mounted on the top track side of the board. Most components are SMD, which makes it easy to build the downconverter without having to make sure that leads on components are kept short as with conventional components. It is best to build the kit in stages starting with the smallest components, followed by the larger ones. The chip capacitors, resistors, & MMIC amplifiers are mounted on the track side of the board. To solder in the chip resistors & capacitors, a pair of tweezers are used to hold the component in place, soldering one side first then the other side. **Before soldering in the MMIC amplifiers, use a sharp knife to scrape around the edges of the drilled mounting holes in the board to clear away any copper that may still be present from drilling.** When soldering in the MMIC amplifiers, the earth connections are bent 90 degrees & passed through the mounting hole in the board & bent out on the other side, & soldered to the groundplane. The input & output legs can be left long, but the earth legs must be kept as short & direct to the groundplane as possible for stability. Make sure that you put the amplifiers in the right way around, MAV devices have a raised dot on the top near the output lead. The MGA86576 has a black dot near the input lead. L1 is made using a 10mm length of silver plated wire wrap wire bent in a U shape around a 6mm drill bit. Next solder in the POS2000 VCO taking note of Pin1s blue indicator Dot. The VCO module should be soldered all the way around to the groundplane for good earthing.

5. Next fabricate the coaxial stub & solder it into place.

7. Connect a short length of insulated hook up wire on the groundplane side of the PCB from the +12volt Input connection of the 150ohm bias resistor, to the input of the 78L08 regulator. This is used to supply power to two areas on the board. Another wire link is also required to power the POS2000.

8. If the downconverter is to be powered via a coaxial cable to the I/F output connector, then the 100nH RF decoupling Choke should be added.

ALIGNMENT & TESTING:

1. You should now be at a stage when you are ready to apply power to the downconverter. First check your construction carefully, & make sure that there are no shorts on the input & output connections of the 78L08 regulator with respect to earth with a multimeter.

2. Connect the downconverter to a suitable satellite receiver or module, & tune the Sat receiver to 965MHz. Check that the voltage from the Satellite receiver is present & around 12 to 14 volts. Attach a suitable 2400MHz antenna to the downconverter & adjust the 5kohm tuning trimpot for a voltage close to 4.35volts on the input pin of the POS2000. This corresponds to an oscillator frequency of 1450MHz for a received signal of 2415MHz., & an I/F output of 965MHz. If you have the MC12179 PLL & 5664MHz crystal option, then check that the PLL is locked by checking that the voltage to the POS2000 is around 4.35volts.

OPTIONS & OPTIMISATION:

1. The 150ohm bias resistor to power the MAV-11 has been selected for a 13.8volt rail only. If you decide to either use the downconverter on higher or a lower voltage, then you will have to recalculate the resistor value to suit the MAV-11s 60mA 5.5volt requirement. If you are going to use a Satellite receiver to directly power the downconverter via the cable, then check the LNB supply voltage from the Satellite receivers LNB connector before connecting to the downconverter. Some Satellite Receivers allow the LNB voltage to be changed between 14 & 18 volts depending on whether Horizontal or Vertical polarization is selected.

2. The converter requires no tuning of the bandpass filters as they have been modeled precisely to cover the frequency ranges advertised using the PCB material from our supplier. Any attempt to adjust the length of the filters printed lines will degrade the performance of the converter. If the PCB needs to be protected then a clear PCB lacquer should be used to protect the copper. **The board should not be finned with solder from a hot soldering iron as the heating process may burn the fiberglass dielectric & cause higher losses in the filters & 50ohm lines & degrade the performance of the converter.**

3. The 2dB noise figure of the converter is very good & very little difference in picture noise level would be realized by going to <1dB or better with a preamplifier. For best results the downconverter should be positioned at the antenna, or alternatively a short <10 Meter length of LDF450 or better cable can be used between the antenna & downconverter.

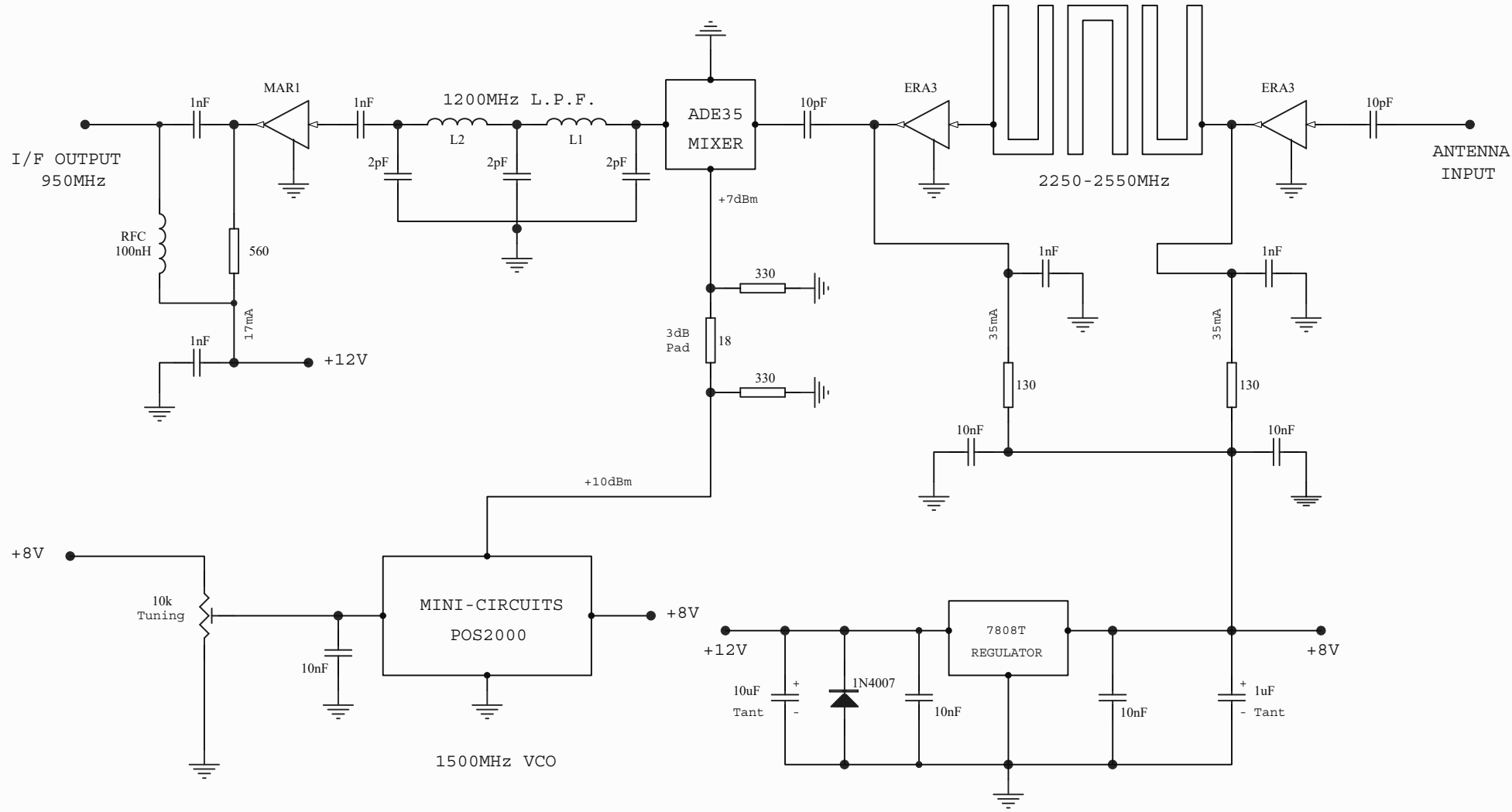

2250-2550MHz ATV DOWNCONVERTER

VK5EME70B

1

2

3

4

A

A

B

B

C

C

D

D

1

2

3

4

PARTS LIST:

| | |
|--|---|
| 1x EME91B PCB | Trim Pots: 5kohm SMD Trimmer |
| 1x 78L08 Regulator | Resistors SMD 1206: 18ohm, 27ohm, 150ohm, 2x 330ohm |
| 1x MGA86576 GaAs MMIC (Black Dot Input) | Capacitors SMD 0805: 8p2 ATC, 5x 1nF, 4x 10nF |
| 1x MAV-11 MMIC Amplifiers (Raised Dot Output) | Tantalum Capacitors: 1uF 25v, 10uF 25v |
| 1x ADE-35 Mixer | 1x 20cm 0.7mm TCW |
| 1x POS2000 VCO Module | 1x length silverplated wire wrap wire (L1) |
| 1x 100nH SMD Coil | 1x Instructions |
| 1x Silver Plated N Connector 4 Bolt Flange Mount | |

OPTIONAL PLL:

| | |
|---------------------|---|
| 1x MC12179 PLL | Resistors SMD: 270ohm, 2x 1kohm, 47kohm, 100kohm |
| 1x 5.664MHz Crystal | Capacitors SMD: 22pF, 100pF, 220pF, 330pF, 1nF, 100nF |
| 1 x 2v7 SMD Zener | |

MISCELLANEOUS:

1x 300mm length of thin 25mm wide brass strip
1x F connector Socket
L1 10mm long silver plated wire wrap wire, U shape around a 6mm dia drill bit.